

| Cable | Ø | R min. |
|----------|------|--------|
| 2x2x0.25 | 7 | 84 |
| 4x1.5 | 10.2 | 120 |
| 4x2.5 | 11.4 | 135 |
| 4x4 | 13.1 | 155 |
| 4x6 | 15.9 | 190 |
| 4x10 | 18.8 | 225 |

Cable output length 2m:
 Power :
 One shielded class 6
 cable coded:
 1,2,3 green/yellow
 Thermal sensors :
 One shielded class 6
 cable (2x2x0.25mm²)
 Brown-White : PTC
 Green-Yellow : KTY84
 Minimum bending radius
 (except for the first 50mm) :
 See table

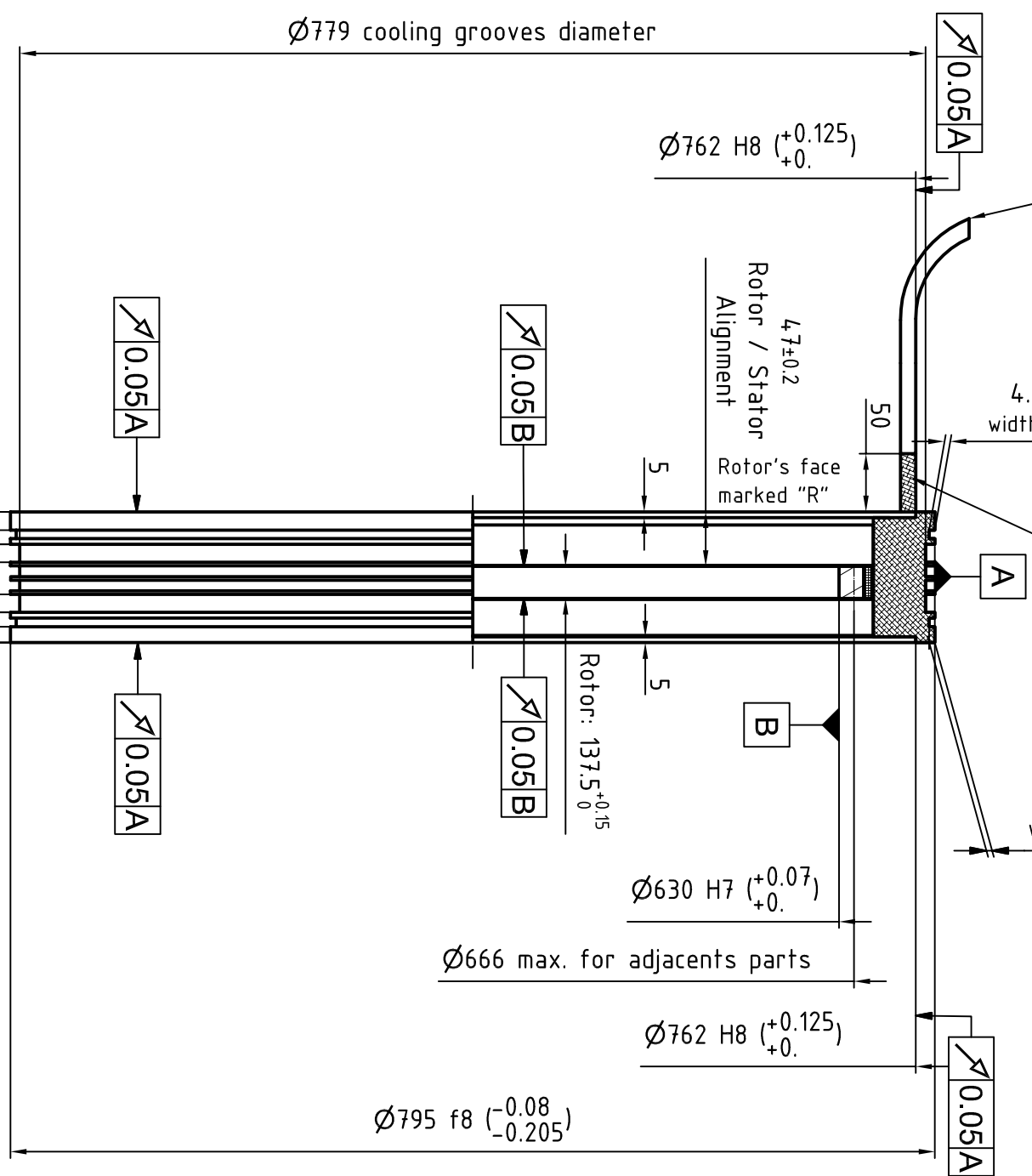

ZONE FREE OF ANY PART
 (cable passing)
 NO STRESS, NO BENDING, IN THIS AREA

4.9 dept, groove
width 7.4 for Oring Ø6

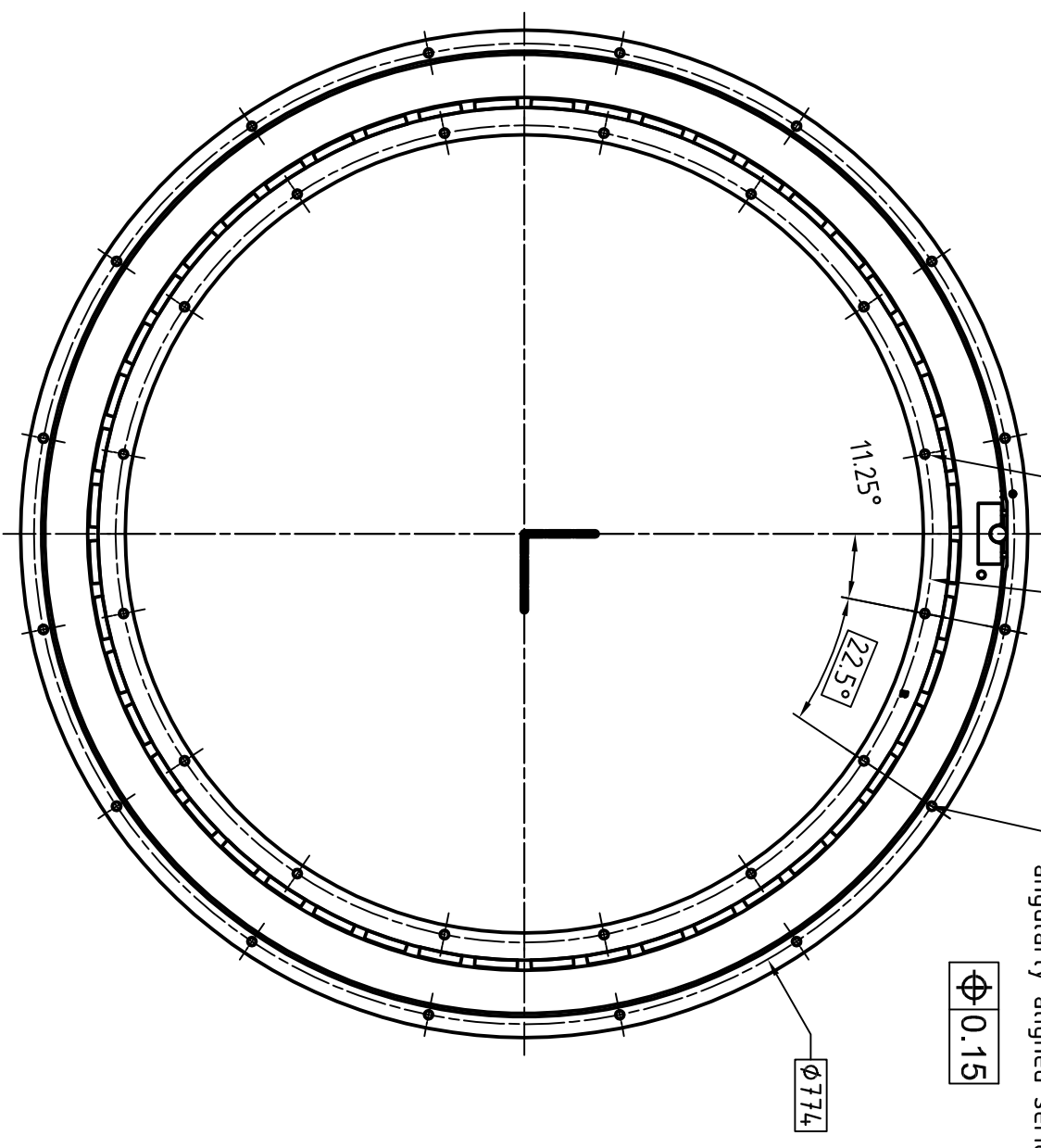

Grooves for input and output of cooling fluid
 Inlet and outlet must be opposite to the power cable.

Nota:

- This drawing is valid only for motors with nominal current lower than 72 Amps.
 - If the nominal current is greater than 72 Amps, please contact us.
 - Rotor is not fitted in the stator
- For more information about mounting see document 800STK0-WA002

CAUTION: For a better safety, it is recommended that the cooling fluid inlet would be made through the hose located on the side opposed to the cabling, while the cooling fluid outlet will be made by the one located on the cable side.

ALXION
 AUTOMATIQUE & PRODUCTIQUE
 Parc Technologique "Les Fossés Jean"
 92712 COLOMBES Cedex
 Tél: 0141306304 - Fax: 0141306136

800STK5M2XXXXXX